

CONTAINERS

HD Roll-Off Container

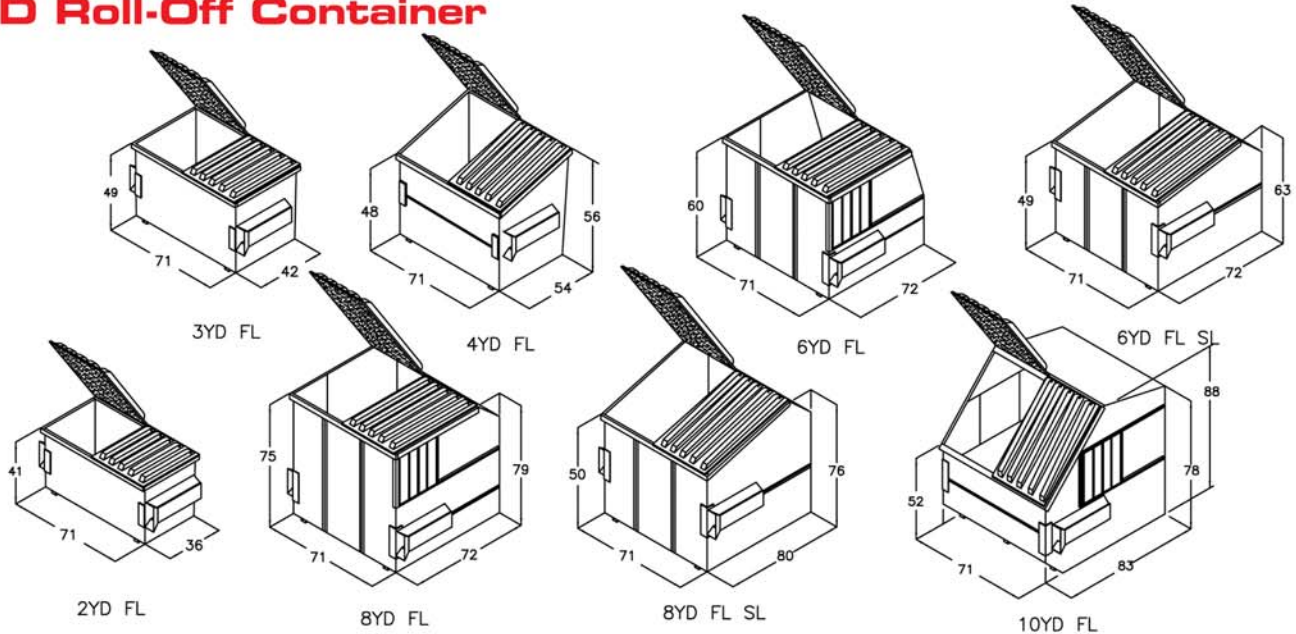

COMPONENTS	2YD FL	3 YD FL	4 YD FL	6 YD FL	8 YD FL	6 YD FL SL	8 YD FL SL	10 YD FL
LIDS	SINGLE OR DOUBLE WALL PLASTIC*	SINGLE OR DOUBLE WALL PLASTIC*	SINGLE OR DOUBLE WALL PLASTIC*	SINGLE OR DOUBLE WALL PLASTIC*	SINGLE OR DOUBLE WALL PLASTIC*	SINGLE OR DOUBLE WALL PLASTIC*	SINGLE OR DOUBLE WALL PLASTIC*	SINGLE OR DOUBLE WALL PLASTIC*
HINGE ROD	1/2" ROUND BAR W/ WASHER AND COTTER PIN	1/2" ROUND BAR W/ WASHER AND COTTER PIN	1/2" ROUND BAR W/ WASHER AND COTTER PIN	1/2" ROUND BAR W/ WASHER AND COTTER PIN	1/2" ROUND BAR W/ WASHER AND COTTER PIN	1/2" ROUND BAR W/ WASHER AND COTTER PIN	1/2" ROUND BAR W/ WASHER AND COTTER PIN	1/2" ROUND BAR W/ WASHER AND COTTER PIN
DOORS	NA	NA	NA	SINGLE WALL PLASTIC OR METAL 30" X 30" (2)**	SINGLE WALL PLASTIC OR METAL 30" X 30" (2)**	NA	NA	SINGLE WALL PLASTIC OR METAL 30" X 30" (2)**
DOOR TRACKS	NA	NA	NA	12 GA FORMED U-CHANNEL W/ SAFETY EDGE	12 GA FORMED U-CHANNEL W/ SAFETY EDGE	NA	NA	12 GA FORMED U-CHANNEL W/ SAFETY EDGE
DOOR OPENING FRONT BUMPERS	NA	NA	NA	7 GA. 2" X 2" FOR EXTRA STRENGTH	7 GA. 2" X 2" FOR EXTRA STRENGTH	NA	NA	7 GA. 2" X 2" FOR EXTRA STRENGTH
BUMPERS	3/16" PLATE FORMED	3/16" PLATE FORMED	3/16" PLATE FORMED	3/16" PLATE FORMED	3/16" PLATE FORMED	3/16" PLATE FORMED	3/16" PLATE FORMED	3/16" PLATE FORMED
PICK UP POCKETS	3/16" PLATE FORMED 30" LONG W/ 10 GA. FULL TOP AND BOTTOM COVER GUSSETS	3/16" PLATE FORMED 30" LONG W/ 10 GA. FULL TOP AND BOTTOM COVER GUSSETS	3/16" PLATE FORMED 30" LONG W/ 10 GA. FULL TOP AND BOTTOM COVER GUSSETS	3/16" PLATE FORMED 30" LONG W/ 10 GA. FULL TOP AND BOTTOM COVER GUSSETS	3/16" PLATE FORMED 30" LONG W/ 10 GA. FULL TOP AND BOTTOM COVER GUSSETS	3/16" PLATE FORMED 30" LONG W/ 10 GA. FULL TOP AND BOTTOM COVER GUSSETS	3/16" PLATE FORMED 30" LONG W/ 10 GA. FULL TOP AND BOTTOM COVER GUSSETS	3/16" PLATE FORMED 30" LONG W/ 10 GA. FULL TOP AND BOTTOM COVER GUSSETS
FRONT, BACK AND SIDES	12 GA.	12 GA.	12 GA. W/ V-BENDS FOR EXTRA STRENGTH	12 GA. W/ V-BENDS FOR EXTRA STRENGTH	12 GA. W/ V-BENDS FOR EXTRA STRENGTH	12 GA. W/ V-BENDS FOR EXTRA STRENGTH	12 GA. W/ V-BENDS FOR EXTRA STRENGTH	12 GA. W/ V-BENDS FOR EXTRA STRENGTH
BOTTOMS	10 GA.	10 GA.	10 GA.	10 GA.	10 GA.	10 GA.	10 GA.	10 GA.
FRONT AND SIDE CHANNELS	11 GA. 1.5" X 2.5" FORMED INTERLOCKING CHANNEL	11 GA. 1.5" X 2.5" FORMED INTERLOCKING CHANNEL	11 GA. 1.5" X 2.5" FORMED INTERLOCKING CHANNEL	11 GA. 1.5" X 2.5" FORMED INTERLOCKING CHANNEL	11 GA. 1.5" X 2.5" FORMED INTERLOCKING CHANNEL	11 GA. 1.5" X 2.5" FORMED INTERLOCKING CHANNEL	11 GA. 1.5" X 2.5" FORMED INTERLOCKING CHANNEL	11 GA. 1.5" X 2.5" FORMED INTERLOCKING CHANNEL
BACK CHANNELS	11 GA. 1.5" X 2.5" FORMED INTERLOCKING CHANNEL	11 GA. 1.5" X 2.5" FORMED INTERLOCKING CHANNEL	11 GA. 1.5" X 2.5" FORMED INTERLOCKING CHANNEL	11 GA. 1.5" X 2.5" FORMED INTERLOCKING CHANNEL	7 GA. 3" X 3" FORMED INTERLOCKING ANGLE	7 GA. 3" X 3" FORMED INTERLOCKING ANGLE	7 GA. 3" X 3" FORMED INTERLOCKING ANGLE	7 GA. 3" X 3" FORMED INTERLOCKING ANGLE
BOTTOM CHANNELS	7 GA. 6" WIDE FORMED CHANNEL W/ FRONT AND REAR CAPPED ENDS	7 GA. 6" WIDE FORMED CHANNEL W/ FRONT AND REAR CAPPED ENDS	7 GA. 6" WIDE FORMED CHANNEL W/ FRONT AND REAR CAPPED ENDS	7 GA. 6" WIDE FORMED CHANNEL W/ FRONT AND REAR CAPPED ENDS	7 GA. 6" WIDE FORMED CHANNEL W/ FRONT AND REAR CAPPED ENDS	7 GA. 6" WIDE FORMED CHANNEL W/ FRONT AND REAR CAPPED ENDS	7 GA. 6" WIDE FORMED CHANNEL W/ FRONT AND REAR CAPPED ENDS	7 GA. 6" WIDE FORMED CHANNEL W/ FRONT AND REAR CAPPED ENDS
DRAIN PLUG	1" NPT PLASTIC	1" NPT PLASTIC	1" NPT PLASTIC	1" NPT PLASTIC	1" NPT PLASTIC	1" NPT PLASTIC	1" NPT PLASTIC	1" NPT PLASTIC
CASTER PADS	OPTIONAL***	OPTIONAL***	OPTIONAL***	NA	NA	NA	NA	NA
CASTERS SWIVEL AND RIGID	OPTIONAL***	OPTIONAL***	OPTIONAL***	NA	NA	NA	NA	NA
AUTOMATIC LID LOCKS	OPTIONAL***	OPTIONAL***	OPTIONAL***	OPTIONAL***	OPTIONAL***	OPTIONAL***	OPTIONAL***	OPTIONAL***
MANUAL LIKD LOCKS	OPTIONAL***	OPTIONAL***	OPTIONAL***	OPTIONAL***	OPTIONAL***	OPTIONAL***	OPTIONAL***	OPTIONAL***
RECYCLING CARDBOARD SLOTS	NA	NA	OPTIONAL (LOCATED ON FRONT)	OPTIONAL (LOCATED ON FRONT INCLUDING METAL DOORS AND LOCKING TABS)	OPTIONAL (LOCATED ON FRONT INCLUDING METAL DOORS AND LOCKING TABS)	OPTIONAL (LOCATED ON FRONT)	OPTIONAL (LOCATED ON FRONT)	OPTIONAL (LOCATED ON FRONT INCLUDING METAL DOORS AND LOCKING TABS)
WEIGHT	530	620	725	945	1110	950	1115	1300